

## (S)TH11

### Closed impellers

# 50 Hz

### STH1102...1121

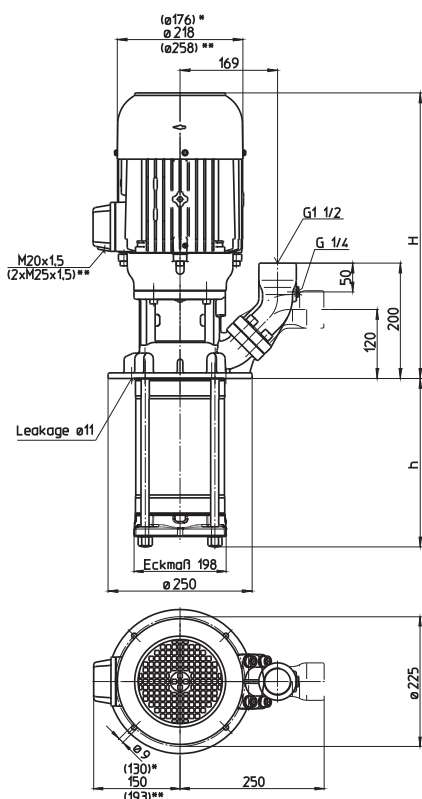

### TH1102...1121

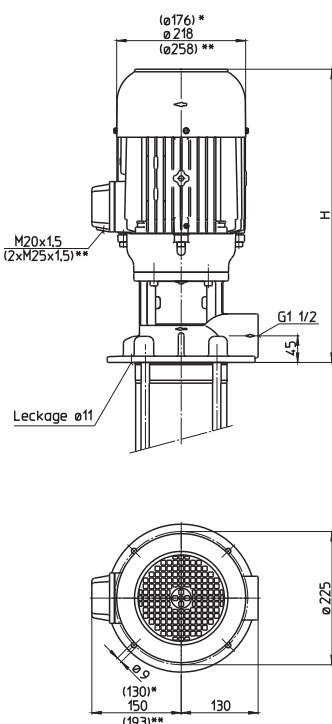

\*) Dimensions for (S)TH1102...1106

\*\*) Dimensions for (S)TH1115...1121

Type	Vol. del. at manom. del. head l/min / m	Height H mm	Depth of immersion h mm	Weight kg	Power kW	Voltage 3 ~ V	Fre- quen- cy Hz	Current A	Speed 1/min
(S)TH1102A180	150/19	433	182	34	1.3	220-240 380-415	50 50	4.85 2.80	2900 2900
(S)TH1103A180	150/29	433	182	35	1.5	220-240 380-415	50 50	5.5 3.2	2880 2880
(S)TH1104A280	150/38	459	278	39	1.7	220-240 380-415	50 50	6.24 3.60	2890 2890
(S)TH1105A280	150/48	492	278	43	1.9	220-240 380-415	50 50	6.84 3.95	2900 2900
(S)TH1106A280	150/58	492	278	45	2.6	220-240 380-415	50 50	9.30 5.35	2880 2880
(S)TH1107A310	150/67	531	310	55	3.0	220-240 380-415	50 50	10.7 6.2	2930 2930
(S)TH1108A380	150/78	531	374	58	3.3	220-240 380-415	50 50	11.6 6.7	2930 2930
(S)TH1109A380	150/88	531	374	59	4.0	220-240 380-415	50 50	14.50 8.35	2920 2920
(S)TH1110A470	150/98		470	60					
(S)TH1111A470	150/106	561	470	67	5.0	220-240 380-415	50 50	17.3 10.0	2920 2920
(S)TH1112A470	150/118			68					
(S)TH1113A500	150/128	561	502	69	5.5	220-240 380-415	50 50	18.9 10.9	2915 2915
(S)TH1114A570	150/138		566	71					
(S)TH1115A570	150/149	640	566	101	7.5	380-415	50	14.3	2950
(S)TH1116A660	150/158		662	103					
(S)TH1117A660	150/168			104					
(S)TH1118A660	150/178			105					
(S)TH1119A760	150/188	640	758	110	9.0	380-415	50	16.7	2955
(S)TH1120A760	150/198			112					
(S)TH1121A760	150/206			115					

## Immersion Pumps

series TH and FH use **closed impellers** in order to minimize power consumption and to optimize hydraulic pump efficiencies.

In addition, the TH series offers high pressures at short immersion depths. Inline pumps of the series FH can be used as **boosting pumps** if provided with positive inlet pressure. This inlet pressure can be provided by the central coolant supply or a feed pump. In such a setup, pumps of the series FH can raise the incoming pressure by up to 26 bar.

**Extended length is possible.** See medium pressure pumps features within the technical information section.

## Applications

Types of fluid  
 Industry water  
 coolants  
 cooling/cutting oils  
 Kinematic viscosity  
 ...25 mm<sup>2</sup>/s (25 cSt)  
 Pumping temperature  
 0...80° C

## Construction

Pump body	cast iron
Cover	cast iron
Impellers	CrNi-steel
Shaft	CrNi-steel
Diffusers	CrNi-steel
Mechanical seal	SiC
O-rings	Viton
Optional:	
Pump body	CrNi-steel
Cover	CrNi-steel

Noise level	
(S)TH1102...(S)TH1106	63 dBA
(S)TH1107...(S)TH1114	71 dBA
(S)TH1115...(S)TH1121	74 dBA

